



Server Technology, Inc.

3-Phase Power in the Data Center

White Paper STI-100-005



Server Technology

HEADQUARTERS -
NORTH AMERICA
Server Technology, Inc.
1040 Sandhill Drive
Reno, NV 89521
United States
1.775.284.2000 Tel
1.775.284.2065 Fax
sales@servertech.com
www.servertech.com
www.servertechblog.com

Western Europe, Middle East and
Africa
Server Technology
Fountain Court
2 Victoria Square
Victoria Street
St. Albans
AL1 3TF
United Kingdom
+44 (0) 1727 884676 Tel
+44 (0) 1727 220815 Fax
salesint@servertech.com

Central Europe, Eastern Europe and
Russia
Niederlassung Deutschland
Server Technology LLC
42119 Wuppertal
Germany
Tel: + 49 202 693917 x 0
Fax: + 49 202 693917-10
salesint@servertech.com

APAC
Server Technology
Room 2301, 23/F, Future Plaza
111-113 How Ming Street,
Kwun Tong, Hong Kong
Direct line: +852 3916 2048
Fax Line: +852 3916 2002
salesint@servertech.com

3-Phase Power in the Data Center

INTRODUCTION

High density computing with increased server implementation, greater equipment densities, increased power demands, cost reduction initiatives, green directives and redundancy are driving the demand for 3-Phase power in the data center equipment cabinet. Several years ago just talking about 3-Phase power distribution at the equipment cabinet would have brought laughs and looks of amazement from your fellow data center employees. Today, there are several simple facts within the data center environment that have created demand for 3-Phase power in the equipment cabinet.

- 1) IT equipment comes standard with universal power supplies that take a wide range of input power and most commonly can support 208 V/230 V power.
- 2) 208 V power is more efficient than 120 V power and with the high cost of power today every little bit helps.
- 3) The amount of power that a 3-Phase power whip can deliver, whether it is 20, 30 or 60 Amp, is almost twice the power or (1.73 times) more than a single phase whip can.
- 4) Cost savings: Lower number of power whips required at the cabinet, less cables at the bottom of the cabinet or under the floor to block air flow, less poles taken up at the power distribution panel, lower number of cabinet power distribution units needed in the cabinet, greater power efficiencies, and less rework required as the data center expands or new equipment is brought in.
- 5) The ability with 3-Phase Wye power to distribute both 208 V and 120 V power from the same cabinet power distribution unit.
- 6) 3-Phase power provides for redundancy and future expansion.

This paper will explore the 3-Phase power, how it works, why it is more efficient and many other advantages it provides to the data center.

3-PHASE POWER

3-Phase power often denoted as 3Φ is the most efficient way to produce and distribute electricity. Nearly all power in the world today is generated as 3-Phase. 3-Phase power combines three electric circuits into one and is supplied over three wires which are typically labeled X, Y and Z in the United States US and L_1 , L_2 and L_3 in the European Union EU. The line voltages between the three possible pairs of wires are XY, YZ and XZ or in Figure 1 are listed as Phases 1, 2 and 3. For industrial applications 3-Phase power is more constant over time making it better suited than single phase power for applications like large industrial loads. This is due to the fact that when a single phase is crossing through zero the two remaining phases are non-zero, either positive or negative, ensuring that the load has a more constant source of power. Each phase is offset from the other by 120 degrees or a $1/3$ of a cycle as shown in Figure 1.

Three-phase Voltage Waveform

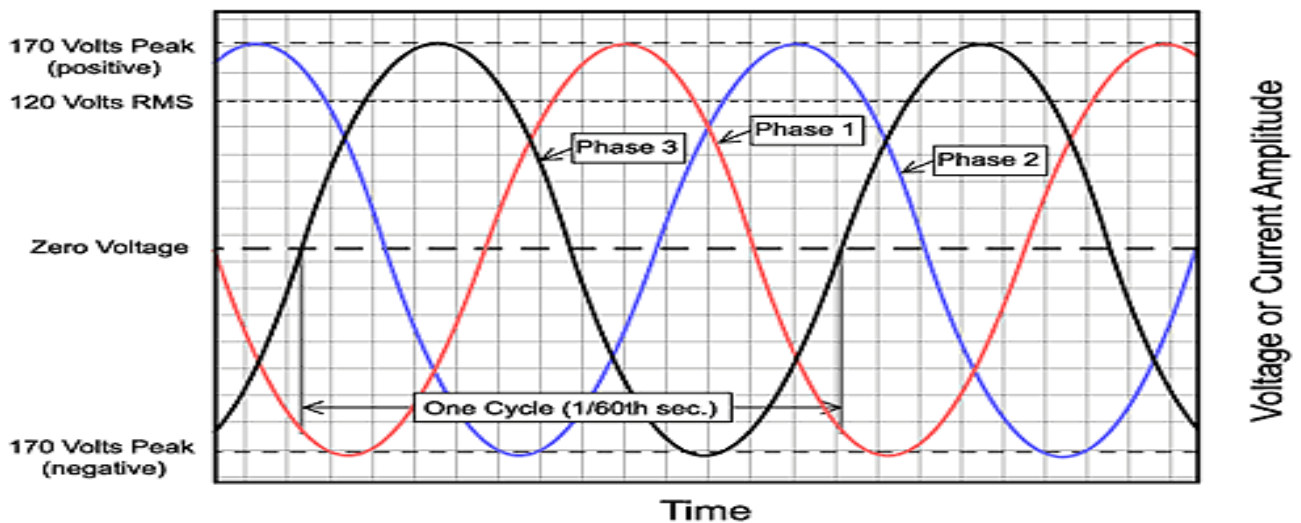

A three-phase system consists of three single-phase waveforms which are displaced in time by $1/3$ of a cycle.

Figure 1

3-Phase power is delivered in either a Delta or Wye configuration source. A delta configuration consists of 3 line wires and one ground wire (see Figure 2). Looking at the wiring diagram it is obvious why it is called a delta configuration as it resembles the Greek letter of the same name Δ . A 3-Phase delta configuration, supplies three 208 V single phase power outputs to power IT equipment via V_{xy} , V_{yz} and V_{xz} .

Three-Phase Delta:

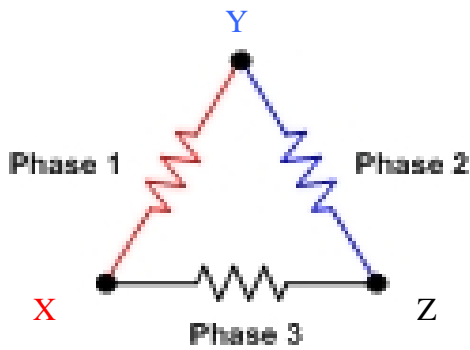

Figure 2

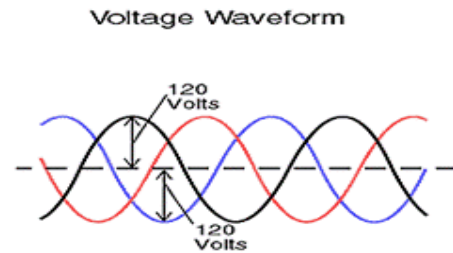

Figure 3

3-Phase Wye power consists of 3 line wires, a common neutral wire, and one ground wire (see Figure 4). Again looking at the wiring diagram it is obvious why it is called a Wye as it is shaped like a "Y". Due to the one additional neutral wire, 3-Phase Wye configurations can supply both 120V and 208 V single phase outputs. 120 V is supplied to a load by connecting the common neutral wire to any one of the three lines X, Y and Z. 208 V is derived by connecting a load to any two of the 120 V lines XY, YZ, XZ and because of this it is often called dual phase power. 208 V is supplied from the two 120 V line voltages as $(120 \text{ V} \times 1.73) = 208 \text{ V}$ not 240 V or $(120 \text{ V} + 120 \text{ V}) = 240 \text{ V}$ as might be expected. This is a result of each phase being just 1/3 a cycle offset in time (see Figures 3 and 5). The voltage does not fully double because no two lines are ever at peak forward or reverse voltage at the same time.

Three-Phase Wye:

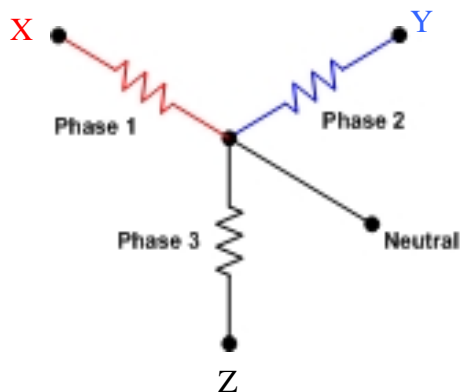

Figure 4

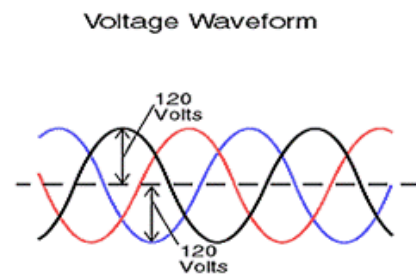

Figure 5

Let's now explore the total power available that a 3-Phase system can deliver to the devices in the cabinet. As an example let's take a look at a common 208 V 3-Phase 30A power whip going to a cabinet. Power is the rate of doing work and is calculated as $P = V$ (volts) \times I (Amps) or VA or Watts in a single phase system. For a 3-Phase system $P = V \times I \times 1.732$ is used to determine VA or Watts. Most people might infer that this whip would deliver 90 amps of current (3 (for three phases) \times 30 A) but it actually delivers 30 A \times 1.732 or 51.96 amps of current to the load. The total kW's delivered on a 3-Phase 208 V 30A power whip is calculated as 208 V \times 30A \times 1.732 or 10.8 kW of power versus a standard 208 V 30 A whip which only delivers 6.2 kW of power. So the 3-Phase system delivers almost twice or 1.732 times the amount of power that a single phase system delivers.

Power Calculations (not de-rated)	
Single Phase Power	Power(P)=V x I =208V x 30A = 6.2 kW
3-Phase Power	Power(P)=V x I x 1.732=208V x 30A x 1.732 = 10.8 kW
Where P = Power in VA or Watts, V=Volts, I=Amps and 1,000 VA= 1 kVA or 1 kW Note: All calculations assume a power factor of 1 (p.f.=1)	

Table 1

Where do we get the magic number of 1.732 or the square root of 3 from?

Each phase in a 3-Phase system is separated from each other of the other 2 phases by 120 degrees. Vector math can be used to determine the voltages between any of the two lines as follows:

X, Y AND Z ARE THE PHASE VOLTAGES

V_{XY}, V_{YZ} AND V_{XZ} ARE LINE VOLTAGES

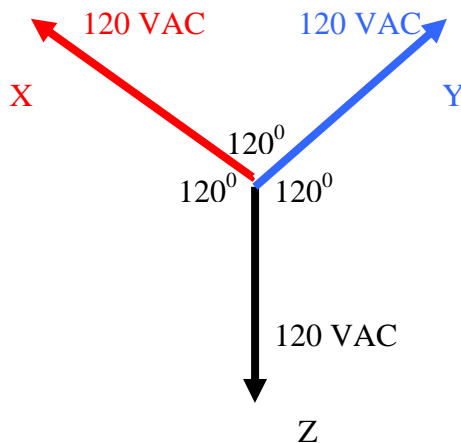

Figure 6

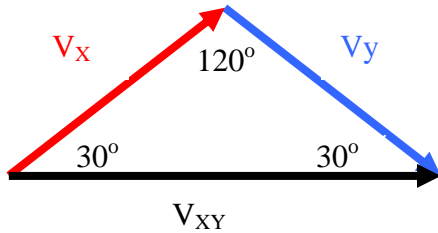

Figure 7

$$\mathbf{V_{XY} = 2 \times (120 \text{ VAC} \times \text{COS} (30)) \text{ OR } (120 \text{ VAC})(2 \times \text{COS} (30)) \text{ OR } 120 \text{ VAC} \times 1.732 = 208 \text{ VAC}}$$

WHERE

$$\mathbf{2 \times \text{COS} (30) = 1.732 \text{ OR THE SQUARE ROOT OF THREE } (\sqrt{3})}$$

LOAD BALANCING

Power calculations for 3-Phase systems become significantly more complicated when the load is “out of balance” or “unbalanced”. Three phase loads are defined as being out of balance when the load current between any two lines X, Y, or Z is significantly different than the load current between the remaining line. Example: $I_{xy} = 15 \text{ A}$, $I_{yz} = 15 \text{ A}$ and $I_{xz} = 0 \text{ A}$. When a load is out of balance, in a Wye configuration, current will flow through the neutral connection causing heating which affects the overall efficiency of the system and the overall amount of power being delivered. Some Cabinet Power Distribution Unit (CDU) suppliers provide three local current load meters (one for each phase) on the CDU to help make load balancing a simple and easy process by instantly knowing what the line current is for the devices being installed in the cabinet. It is much easier to use a device that measures the actual line current than having someone try to perform these calculations.

OTHER FACTORS TO CONSIDER WHEN CALCULATING POWER (DE-RATING)

When doing power calculations the user should not expect to utilize the full current or power rating that the whip is providing to the cabinet as a safety or de-rating factor needs to be applied. The NEC (National Electric Code) specifies a 20% or x .8 de-rating factor is applied to rack mounted CDU's. This is a very reasonable and practical factor to be used. The power calculations used in Table 3 have a .8 safety factor applied. Depending on the facility and the specific constraints some IT Managers will apply either a lower or higher factor.

UNIVERSAL POWER SUPPLIES - IT EQUIPMENT AND CABLE MANAGEMENT

Virtually all IT equipment today comes standard with a universal power supply. These power supplies vary but looking at the one at my desk for my DELL laptop computer shows an input of 100 to 240 volts at 50 - 60 Hz. The confusion as to what power can be connected to it seems to lie with the power cord. In most cases IT equipment shows up with a NEMA 5-15 P plug on it leading the user to believe that they have purchased a 120 V device when in reality it can be just as easily be powered with 208 V or 230 V power (see Figure 8). (Note: Each device should be reviewed to verify 100 V to 240 V compatibility before power is applied.) In these cases the standard power cords delivered with the equipment should not be used and swapped with a cord that has a IEC C13/C19 on one end to plug into the IT device and either IEC C14 or C20 on the other for plugging into the Cabinet Power Distribution Unit (CDU) (see Figure 9). Along with purchasing cables that allow your devices to be 208 – 230 V powered there is the extra advantage of being able to order cables in the proper lengths. This avoids cable management problems, giving the equipment cabinet a cleaner look and making it much easier to install new equipment or service the existing equipment along with not interfering with airflow.

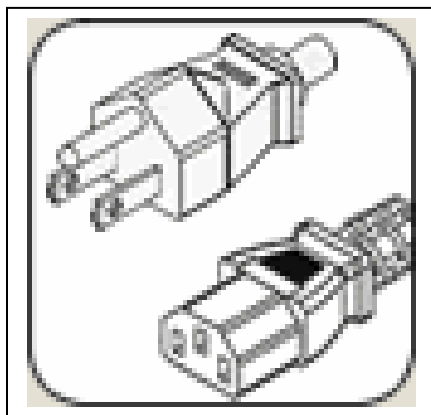

Standard
Power
Cord –
Exchanged
for new
power cord

Figure 8

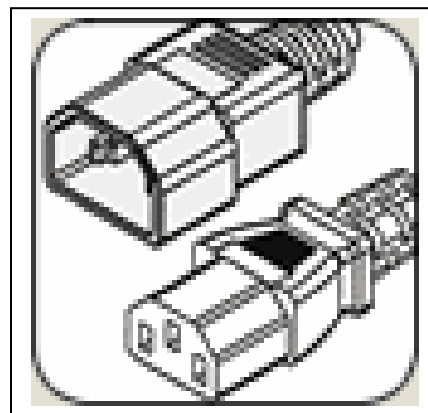

New Power
Cord –
Allows
connection
to 208/230 V
power
sources

Figure 9

GREEN DIRECTIVES – POWER EFFICIENCY GAINS

Organizations committed to reducing their carbon footprint in their data centers are doing power/energy assessments and are finding many ways to save large amounts of power. Some of the more common ways to save energy in the data center are:

- 1) Improving cooling efficiency using best practices
- 2) Virtualization

- 3) Turn-off idle IT equipment
- 4) Consolidation
- 5) Enable CPU power management feature on IT equipment
- 6) Purchase IT equipment with high efficiency power supplies
- 7) Use high efficiency UPS's
- 8) Adopt power distribution at 208/230 V

There is a simple way to increase the efficiency in your data center by a few percentage points. As there is a 2% efficiency gain just by going from 120 V to 208 V power and a 3% efficiency gain going from 120 V to 230 V power with many devices. To determine what the gain is on your servers and other devices review the power supply specification and look at the efficiency % based on the various input voltages. The example below is taken from a HP power supply specification sheet for their ProLiant® DL380 server (see Table 2).

Power Supply Specification	HP ProLiant DL380 Generation 5 (G5)		
Operational Input Voltage Range (Vrms)	90 to 264		
Nominal Input Voltage (Vrms)	120	208	230
Efficiency %	82	84	85

Table 2

HIGH DENSITY POWER - AMOUNT OF POWER DELIVERED

Increased cabinet densities, blade servers and other high density installations now require more power is brought to the cabinet level. The amount of power required is a function of the equipment installed in the cabinet, whether redundancy is required and if the data center is planning for future expansion or additional equipment to be installed in the cabinet.

The average kW per cabinet in the typical data center has jumped from 3-4 kW's to 6-8 kW's per cabinet depending on the industry and the application. This is a trend that is likely to continue with future predictions as high as 33 kW per cabinet on average by 2011 as reported by the Gartner group.

Table 3 shows the amount of power in kW's being delivered, depending on the different power drops available today.

Circuit Power Drop Comparison

Power Drop	Delivered Power in kW (derated)	# of Branch Circuits	# of Poles	Branch Circuit Protection	120 V Support	208 V Support
120 V 15 A	1.44	1	1	N	Y	N
120 V 20 A	1.92	1	1	N	Y	N
120 V 30 A	2.88	2	1	Y	Y	N
208 V 20 A	3.33	1	2	N	N	Y
208 V 30 A	4.99	2	2	Y	N	Y
208 V 3-Phase 30 A	8.64	3	3	Y	Y (Wye)	Y
208 V 3-Phase 60 A	17.28	6	3	Y	Y (Wye)	Y

Table 3

Looking at the table above it becomes clear that today's increased densities require new power solutions at the cabinet level. For example, why run just 208 V 20A power, which provides 3.33 kW a drop when you can run 208 V 30 A power and get 4.99 kW per drop to the cabinet at roughly the same cost. It also becomes clear that with the average kW densities running in the 6-8 kW range that in many installations including redundancy 208 V 30 A 3-Phase power is required to cost effectively meet today's high density requirements. When working with a PDU supplier make sure they have a complete product offering that includes 16A, 20A, 30A, 32A, 60A current capabilities along with 120 V, 208 V, 208 V 3-Phase and 400 V 3-Phase product solutions. Also, make sure that key operating features are available such as local and remote current monitoring, environmental monitoring, SNMP traps, email alerts, secure web based GUI, out of band serial connection, and the ability to remotely reboot locked up servers and network devices.

INSTALLATION EXAMPLE

A simple installation example is a good way to illustrate how many power whips are required, including redundancy, to operate ten (10) HP Model DL-380-GL servers requiring 7.4 kW of power.

Server Cabinet		
Server 1	HP DL-380-G5	1000 W
Server 2	HP DL-380-G5	1000 W
Server 3	HP DL-380-G5	1000 W
Server 4	HP DL-380-G5	1000 W
Server 5	HP DL-380-G5	1000 W
Server 6	HP DL-380-G5	1000 W
Server 7	HP DL-380-G5	1000 W
Server 8	HP DL-380-G5	1000 W
Server 9	HP DL-380-G5	1000 W
Server 10	HP DL-380-G5	1000 W
Upon start up 10,000 W		
Consumed 7,425 W		

Table 4

Installation Example: Server Cabinet with 7.4 kW power demand

Solution/Wiring Configuration:

Solution 1:

(3) 120 V, 30 A circuits

(8.6 kW delivered de-rated)

(6) circuits required for redundancy

Solution 2:

(2) 208 V, 30 A circuits

(9.98 kW delivered de-rated)

(4) circuits required for redundancy

Solution 3:

(1) 208 V 3-Phase, 30 A circuit

(8.6 kW delivered de-rated)

(2) circuits required for redundancy

Outlet sequencing, within the CDU, is used to handle the increased power demands due to in-rush currents during startup. It is clear from this installation example that by providing higher density power to the cabinet and more specifically 3-Phase power that the number of drops run to the cabinet is greatly reduced resulting in significant cost savings throughout the data center.

COST SAVINGS AND OTHER ADVANTAGES TO 3-PHASE POWER

There is a definite cost associated with each power whip that is run to a cabinet. Estimates vary depending on who is doing the work and the location but on average it cost between \$750 and \$1,000 per whip. So by running 3-phase power there is a definite cost savings associated with running a lower number of whips versus a higher number.

With fewer whips delivering more power there is a secondary, inherent savings from lower infrastructure costs by using less poles at the PDU or the power distribution panel (see Table 3). With a lower number of cables under the floor and in the bottom of the cabinet there are fewer objects to block the air flow within the raised floor. An optimized installation makes for a cleaner work environment and less confusion and problems during installation and maintenance.

Along with reducing the number of cables being run with three phase power, is the added advantage of requiring fewer Cabinet Power Distribution Units within the cabinet. This provides additional cabinet space for other devices along with eliminating equipment which again blocks airflow. The concept of 0 U CDU's that are mounted in the back of cabinets are now giving way to Modular 3-Phase CDU's that can be mounted in the sides of cabinets. In some installations today even the back of the cabinet does not have enough room to support multiple CDU's.

By running 208 V or 230 V power there are cost savings due to efficiency gains instead of running 120 V within the cabinet. In many case these gains are 2-3 % or greater depending on the device and the efficiencies of its power supply at higher input voltages. This information is readily available for most IT equipment through the manufacturer.

The average refresh rate of IT equipment, is every 3-5 years. Considering the increased power demand and the fact that this trend is very likely to continue, it makes sense to plan for future power demands. First, consider changing all equipment over to 208 V power. Next plan for near term infrastructure needs with 208 V single phase power and possible current or future requirements such as 208 V/400 V three-phase power.

High availability, high demand, 7 x 24 Tier III and Tier IV data centers continue to become more common with redundant power sources (A and B power drops) within the cabinet. When redundant power is required the amount of power required within the cabinet doubles. These higher densities in many cases require the user to go to 3-Phase power to meet this increased demand.

WHAT DOES THE FUTURE HOLD?

Various arguments are being made for DC power in the data center as well as moving to 230V single phase and 400 V 3-Phase power in North America like much of the rest of the world to help meet the increased power demands within the data center. It is clear that increased power demands and greater equipment densities are here to stay for the foreseeable future. The Server Technology White Paper Blade Server Power Solutions: Cabinet Level Power Distribution Solutions for High Density Cabinets STI-100-001 discusses the current power demand trends within the data center.

CONCLUSION

For new data centers, equipment refresh and renovations 3-Phase power should be considered as the primary power choice. The advantages and cost savings are clearly there, while the disadvantages or risks are minimal. With the few remaining 120 V powered devices in the facility, 3-Phase power still has the ability to support them.

For some IT Managers the choice of going with 3-Phase power is being made for them as increased power demands and redundancy have forced the issue within their facility along with cost analysis information showing the increased savings versus single phase power. If your IT equipment is located in a Co-Location facility or an older data center that is running out of power you may not have the choice to run 3-Phase power but it should always be considered as an option.

With definite cost and efficiency advantages as shown in this paper 3-Phase power is becoming the power option of choice today for many data centers. In some locations, this is now being seen as more of a requirement than as an option as densities continue to increase.